

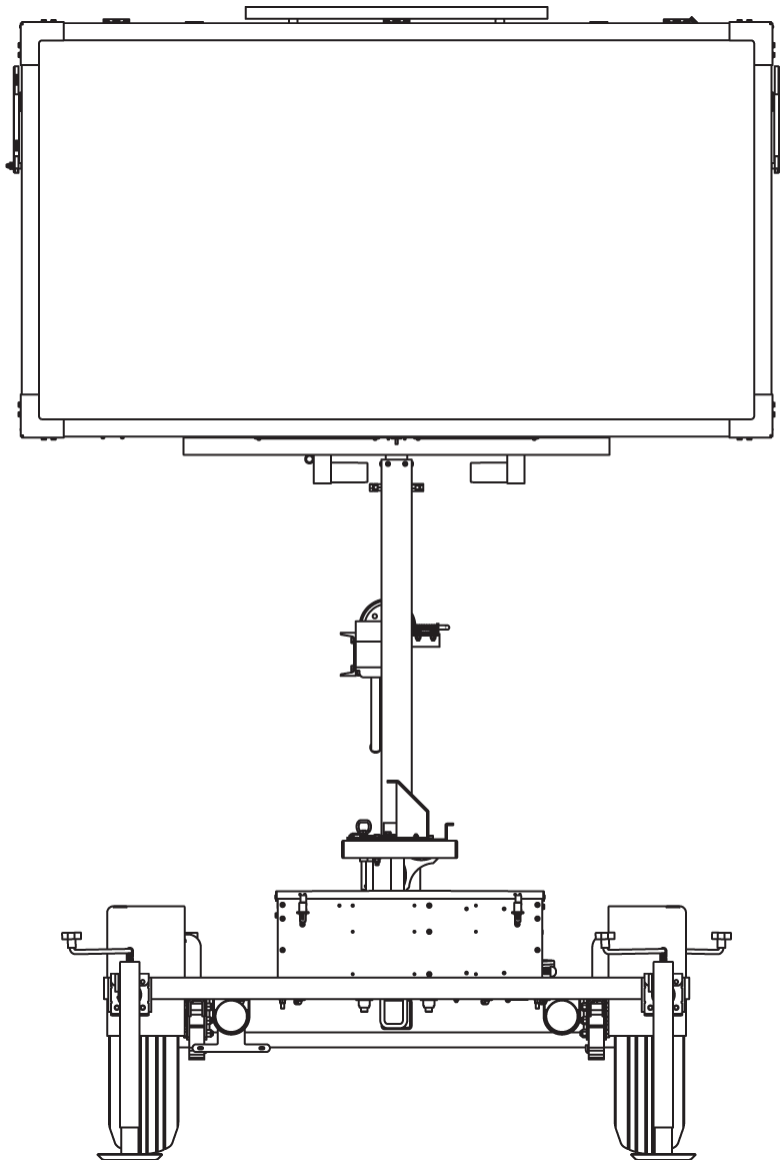

WSD-1005
09 2017

METRO™ MESSAGE SIGNS

MODEL WVTMM
PRODUCT SPECIFICATIONS | SEPTEMBER 2017



1. SYSTEM

- 1.1. Description
- Wanco® designed the Metro™ message signs for use in metropolitan areas and wherever trailer size is a concern. Metro signs provide the visibility and legibility of other Wanco message signs, but with a smaller footprint. Metro message signs provide information to the public on a full-matrix LED display. The display can present messages as text, graphics, or a combination of both.
- These signs are portable and self-powered, requiring no permanent installation or wiring. Their compact design makes them highly maneuverable and easy to deploy. They can be towed by most vehicles.
- Messages are programmed using a self-contained onboard controller, making a laptop or external controller unnecessary. The signs come configured with preprogrammed standard messages, and users can create custom messages easily.
- For optimal positioning, the message sign display panel rotates independent of the trailer and its height is fully adjustable. Jack-legs provide stability.
- Power is provided by maintenance-free batteries, which are charged by an automated solar charging system.
- 1.2. Models
- Two Metro models are available. The larger display size is wider to accommodate more characters per line of text.
- 1.2.1. WVTMM-L
- Metro matrix message sign with large-size display
- 1.2.2. WVTMM-M
- Metro matrix message sign with medium-size display
- 1.3. Temperature limits
- | | |
|-----------|------------------------------|
| Operating | –29 to 165°F (–34 to 74°C) |
| Storage | –40 to 185°F (–40°C to 85°C) |
- 1.4. Standards
- Compliant in accordance with:
- NTCIP Version 2
- NEMA TS 4-2005 Section 2 for ambient temperature, vibration, shock, electro-static discharge (ESD), and radio interference

2. FEATURES

- 2.1. Setup
- Heavy-duty hand-winch allows one person to easily raise and lower the sign display
 - Tower rotates 360 degrees for optimal positioning
 - Lock-pin holds tower in place during operation
- 2.2. Operation
- Self-contained onboard control system, no laptop required
 - Full-color touchscreen controller with high-resolution display
 - Multi-level password protection restricts access to control software
 - Preprogrammed text messages, symbols and graphics
 - Easily center each line of text
 - Internal clock facilitates built-in schedule programming

- Multiple alphanumeric fonts
 - Control box can be locked to prevent unauthorized access
 - Optical lenses and sunshades increase visibility and performance
 - NTCIP compliant
- 2.3. Power system
- Battery powered and solar charging
 - Energy-efficient operation results in long run times
 - Solar panels charge batteries automatically without intervention
 - Charging system shuts down when batteries are fully charged, preventing damage
 - Power system allows battery charging with solar panels or commercial power
 - Cooling fan protects battery charger from overheating
 - Battery box can be locked to prevent unauthorized access
- 2.4. Maintenance
- Individual display modules can be replaced easily
 - Standard trailer tires
 - Heavy-duty bolt-on steel fenders can be replaced if damaged
 - Durable powder-coat finish resists the elements
- 2.5. Application
- Common uses for Metro signs include urban areas where a sidewalk is the only place to put a message sign, congested streets where a full-size sign might impede traffic, and anywhere a full-size sign is not practical. Common applications include:
- Roadwork zones
 - Traffic calming
 - Road closures
 - Emergency response
 - Public events

3. DISPLAY

3.1. Cabinet

3.1.1. Description Weather-resistant cabinet contains display modules and related electronics. Hinged door with full-size display window protects electronics and provides access for maintenance. Clasps hold door closed during operation and the door can be locked with user-supplied padlock.

See "Options and Optional Equipment" for color display.

3.1.2. Size Large display 96" x 48" x 6" (244 x 122 x 15cm) W x H x D

Medium display 71" x 48" x 6" (180 x 122 x 15cm) W x H x D

3.1.3. Material Aluminum sheet, 5052-H32, 0.062" (1.575mm) thick

3.1.4. Construction Panels are riveted together, with internal ribs to add lateral strength

- 3.1.5. Door Cabinet door is aluminum extruded frame with sheet metal corner brackets. Stainless steel butt hinges are bolted to top of cabinet and door.
Window is anti-glare Lexan® solar-grade polycarbonate, 0.150" (3.81mm) thick.
When sign is in stored position, door fully opens to service the sign cabinet interior. Telescoping prop-slides, one on each side of the cabinet, hold door open.
- 3.1.6. Finish Cabinet and door are coated with oven-baked, flat-black, powder-coat finish to ensure durability and corrosion protection. Assemblies are high-pressure phosphate-washed prior to finish coat.
- 3.1.7. Wiring Wiring service loop from computer box to display cabinet is routed inside liquid-tight loom and P-clamped to trailer frame. Service loop length is designed to allow sign rotation. All wiring connectors and procedures are per CSA standards.
- 3.1.8. Storage When lowered for storage and transport, the display cabinet rests in two support cradles, parallel to the trailer length, no locking pins required
- 3.2. Display matrix
- 3.2.1. Description The display matrix is comprised of a series of display modules laid out in a grid across the inside of the display cabinet. Each module has a matrix of LEDs installed on its face, which light up to show a portion of the configured message. Each module features the necessary electronics and coatings to ensure outstanding performance and durability.
- 3.2.2. Display modules
- | | |
|----------------|--|
| Modular design | Allows any display module to be installed in any position in the matrix without repositioning DIP switches |
| Wiring | Modules have quick-connect electrical connectors for easy servicing. All wiring terminates at a single terminal strip inside the display cabinet. |
| Replacement | Each module can be exchanged in less than two minutes. The only tool needed is a 5/16-inch nut driver socket or slotted screwdriver

After a new module is installed, a one-step initialization process causes each module to sense its position in the full-matrix display. Initialization is accomplished using the sign's controller. |
| Size | 16.0" (40.6cm) wide by 13.13" (33.3cm) high, nominal |
| Material | FR4 glass-reinforced epoxy laminate, double-sided, black solder mask with white silkscreen

Board thickness, 0.094" (2.388mm)

Copper size, 1 oz. (28.4g) |

	Coating	5-mil, military-spec, low-VOC, silicone conformal coating (Dow Corning 1-2577) provides long-term protection against moisture and other atmospheric contaminants, resists corrosion and shorts due to high humidity
	Vibration mounts	All display modules are mounted on rubber vibration-isolation mounts, decreasing risk of physical shock during transport and isolating characters from chassis ground
	Humidity limits	Conformal coating rated to 95% relative humidity
3.2.3.	Pixels	Two LEDs form a “pixel”
	Pixel size	0.5" x 0.5" (13 x 13mm)
	Full matrix	Large sign: 60 pixels wide by 30 pixels high, 1800 pixels total Medium sign: 48 pixels wide by 30 pixels high, 1440 pixels total
	Display module	12 pixels wide by 10 high, 120 pixels total
	Pixel pitch	34mm, horizontal and vertical
3.2.4.	LEDs	Technology AllnGaP II (aluminum indium gallium phosphide) technology, T-1¼ size, through-hole auto-insertion
	Color range	Amber, 589.5 to 592.0 nm
	Current	100 mA peak-pulsed forward current
3.2.5.	Lenses and visors	Each pixel has a snap-in optical lens over the LEDs, enhancing the brightness and angularity of each pixel while reducing power consumption. A polycarbonate visor shades each row of pixels to eliminate glare caused by direct sun exposure. The sunshades snap onto the display module without tools. The lenses snap into the sunshades. These enhancements enable the message sign to operate with approximately half the power consumption of other message signs. As a result, the system is fully functional using fewer solar panels and batteries, while providing outstanding brightness and readability in all lighting conditions, and 30-day battery autonomy without sun. Reducing the number of solar panels and batteries also lowers the trailer weight and reduces maintenance costs.
3.2.6.	Viewing angle	Total viewing area with optical lenses, 50 degrees
3.2.7.	Brightness	Factory preset for optimal viewing and power consumption
3.2.8.	Auto dimming	Two photocells detect ambient light on the message sign; the message sign computer adjusts the brightness of the LEDs accordingly, dimming display brightness in darkness, increasing to full brightness in daylight Photocells are mounted inside the sign cabinet, one facing rear and one facing front

3.2.9.	Software design	Driver	LEDs controlled through 30mA pulse-width modulation design
		Addressing	Each display module address is selected through a software command; no DIP switches are used. The address does not change until reprogrammed, preventing the message from shifting due to an individual module failure.
		Pixel test	Each module is equipped with individual pixel failure notification
3.2.10.	Fonts	12 fonts	
			See Exhibit A for font samples and additional font information
		Default size	5 x 9 pixels (W x H), 6.32" x 11.67" (160 x 296mm) Large display: 3 lines of 10 characters per line, maximum Medium display: 3 lines of 8 characters per line, maximum
		Smallest size	4 x 5 pixels (W x H)
		Largest size	11 x 23 pixels (W x H)
		Other sizes	See Exhibit A

4. CONTROL SYSTEM

4.1.	Description	Self-contained onboard computer, comprised of a power control unit (PCU), located behind display modules inside the message sign display cabinet; and a display control unit (DCU), located inside control box on the back of the message sign display cabinet.
4.2.	Control box	
4.2.1.	Size	12.3" x 11.7" x 5.3" (31.2 x 29.7 x 14.4 cm) W x H x D
4.2.2.	Material	0.08" aluminum
4.2.3.	Mounting	Securely fastened to the sign cabinet with six mounting screws
4.2.4.	Door	Front-panel is a door, hinged on the left, which opens fully.
4.2.5.	Latch	Two quarter-turn latches on front of control box door keep hinged door closed. Both latches are keyed and can be locked.
4.2.6.	Finish	Cabinet and door are coated with oven-baked, equipment-white, powder-coat finish to ensure durability and corrosion protection. Assemblies are high-pressure phosphate-washed prior to finish coat.

- 4.3. Control panel
 - 4.3.1. Touchscreen
 - Display
 - Full color, backlit, 7-inch display
 - Capacitive touch panel
 - 800 x 480 pixels, W x H
 - Display automatically shuts off after 10 minutes of inactivity
 - Interface
 - Menu-based structure, accessed with virtual buttons on the touchscreen display, provides access to all sign functions including programming messages
 - Virtual keyboard appears when required for text entry
 - Multi-level password protection restricts access
 - 4.3.2. LED indicators
 - Indicates the following status conditions:
 - Solar charging system is charging batteries
 - System power shutdown occurred
 - Programmed schedule is active
 - Power to optional radar device is on
 - 4.3.3. Data port
 - 1 USB port for connecting optional handheld touchscreen controller and for downloading data from optional traffic data collector (if installed)
 - See “Options and Optional Equipment”
- 4.4. PC boards
 - 4.4.1. Coating
 - 100% coated with military-spec, low-VOC, silicone conformal coating to provide long-term protection against moisture and other atmospheric contaminants. Resists corrosion and shorts due to high humidity.
 - 4.4.2. Humidity limits
 - Conformal coating rated to 95% relative humidity
- 4.5. Serviceability
 - Four plunger panel latches allow the control panel to be removed, providing access to internal components inside control box; PCU is accessible by removing display modules inside message sign display cabinet.
 - All wiring connections have quick-connect plugs.
- 4.6. Controller software
 - 4.6.1. Standards
 - Fully NTCIP-compliant
 - 4.6.2. Security
 - Three levels of password protection
 - 4.6.3. Message programming
 - Instant access to program new messages
 - Extremely easy to program

4.6.4.	Message types	Quick-messages	Easy quick-message activation
		Permanent	Over 90 preprogrammed permanent messages, including arrows and FHWA standards
		Changeable	250 changeable messages stored in NV flash
		Temporary	10 temporary or volatile messages, for ITS systems
		Blank	Easy sign blanking/power off
4.6.5.	Interface display	WYSIWYG (What You See Is What You Get) while programming	
4.6.6.	Text alignment	Selectable: left, center, or right; and top, middle, or bottom	
4.6.7.	Fonts	Selectable: see Exhibit A	
4.6.8.	Blinking	Each character can individually blink	
		Individual lines of a multi-line message can blink	
		The entire message can blink	
		Adjustable timing and duty cycle	
4.6.9.	Message pages	Maximum 12 sequential “pages” per message, sequencing speed from 0.1 to 25.5 sec.	
4.6.10.	Scheduling	Real-time clock and calendar with DST control	
4.6.11.	Arrow board functions	Sign can display any of the following 12 full-size arrow functions	
		Modes	Flashing left or right arrow
			Flashing double arrow
			Flashing four-corner warning
			Flashing caution-bar warning
			Sequencing left or right stem arrow
			Sequencing left or right walking arrow
			Sequencing left or right chevron arrows
			Alternating diamonds
			(for samples, see Exhibit B)
		Bold graphics	Each arrow and bar is 5 pixels wide
4.6.12.	Configuration	Menus provide access to all message sign configuration settings	
4.6.13.	Troubleshooting	Status and diagnostic menus provide message sign information to assist in troubleshooting	

5. TRAILER

- 5.1. Frame All welded structural steel
- 5.2. Fenders Round full wheel coverage fenders with inner splash panel on each fender. Fenders are bolted to the trailer frame.
Material: 16ga steel
- 5.3. Tie-downs Three tie-downs: one on each front corner of frame, one centered on rear of frame
- 5.4. Finish Frame is coated with oven-baked, safety-orange powder-coat finish to ensure durability and corrosion protection. Assemblies are run through a five-stage, high-pressure phosphate-wash prior to finish coat.
See "Options and Optional Equipment" for color options.
- 5.5. Axle assembly 2000 lb. (907kg) capacity, 5 on 4.5" B.C. idler hub
- 5.6. Springs Double-eye leaf springs
- 5.7. Tires ST205/75D15 steel-belted trailer tires, load rating B
- 5.8. Drawbar
- 5.8.1. Construction Telescopes inside receiver sleeve welded under trailer frame. Removable for shipping and for added theft protection if needed. Secures with two 1/2-inch (12mm) diameter bolts.
- 5.8.2. Material Square tubing, 3" x 3/16" wall (7.62cm x 0.476cm wall)
- 5.8.3. Jack Top-wind swivel, 800-lb. (363kg) capacity with caster wheel to make moving trailer easier
- 5.8.4. Tow hitch Standard 2-inch ball coupler tow-hitch, SAE Class 2, 3500-lb. (1588kg) capacity. Bolts to drawbar, removable and replaceable.
See "Options and Optional Equipment" for tow-hitch options.
- 5.8.5. Tow chains Two high-test proof coil chain assemblies, with "latching" S-hooks for towing. Chains attached to drawbar with quick connectors.
Material diameter 0.406" (10.3mm)
Working load limit 5400 lbs. (2450kg)
Breaking force 16,200 lbs. (72kN)
- 5.9. Stabilizer jacks Four swivel jacks, each with 2000-lb. (907kg) capacity, mounted on corners of trailer frame
- 5.10. Wind resistance In the deployed position, the maximum sustainable wind speed before overturning, when supported by the standard jack stands with tires off the ground, is 50 mph (80km/h)

5.11.	Taillights	Two round, sealed, combination stop, turn and taillights
5.12.	License plate	License plate holder, lighted by left taillight
5.13.	Reflectors	Sides of trailer have amber reflectors near front and red reflectors near rear See "Options and Optional Equipment" for reflective tape
5.14.	Wiring	
5.14.1.	Description	Wiring to connect tow vehicle and trailer for trailer taillights is installed inside drawbar, with pigtails and connectors at both ends; no crimping required
5.14.2.	Trailer plug	A sealed, molded, 4-square connector plugs into harness under trailer
5.14.3.	Tow-vehicle plug	Two-piece assembly with 4-flat molded connector on harness plugs into tow vehicle Meets SAE J1239 See "Options and Optional Equipment" for tow-vehicle plug options
5.14.4.	Protection	All trailer wiring encased in UV protective loom, and attached with P-clamp riveted to trailer frame; no exposed wires
5.15.	Tower assembly	
5.15.1.	Function	Sign cabinet is raised and lowered on a telescoping tower
5.15.2.	Tower construction	Two sections of square steel tubing with the inner section telescoping inside the outer section. The inner section is zinc plated to prevent corrosion. Nylon guide blocks keep the sections tight, eliminating the need for greasing the tower and preventing dirt from building up on the inner tower section. Dirt would cause performance problems and maintenance issues.
5.15.3.	Swivel base	A steel tubular weldment is bolted to the trailer frame. The outer tower section rotates on a thrust bearing and washers inside the swivel base, reducing rotating friction.
5.15.4.	Finish	Tower sections and swivel base are treated for corrosion resistance
5.15.5.	Height	At fully deployed height, 84" (213cm) from ground to bottom of display cabinet
5.15.6.	Height lock	Spring-loaded locking pin prevents tower from falling if the winch or cable were to fail. Also locks tower when fully lowered into travel position.
5.15.7.	Winch assembly	Function Capacity Brake Cable
		Hand-operated winch raises and lowers sign cabinet 1500 lbs. (680kg) Safety friction-brake prevents display cabinet from falling if operator loses grip on winch handle 1/4" (6.35mm) diameter galvanized aircraft cable

- 5.15.8. Rotation Sign rotates by hand, pivoting 360 degrees on tower
- 5.15.9. Rotation lock Sign rotation is locked with a locking pin inserted through a horizontal plate mounted to tower
See "Options & Optional Equipment" for rotation brake option
- 5.15.10. Sight tube A sight tube for aiming the message sign in desired direction is mounted to the underside of the display cabinet frame

6. POWER SYSTEM

- 6.1. Description Electronics powered by batteries, which are charged automatically with integrated solar charging system
- 6.2. Battery box
 - 6.2.1. Function Holds batteries and remote charger
See "Options and Optional Equipment" for heavy-duty secure battery box
 - 6.2.2. Construction Riveted all-steel construction
All parts powder-coated before assembly
Divider panel inside box separates batteries from electronics
Louvers provide ventilation
Latches keep cover closed and can accept user-supplied padlocks
 - 6.2.3. Location Centered over axle between fenders, bolted to trailer frame
- 6.3. Batteries
 - 6.3.1. Description Four deep-cycle golf-cart-type batteries, wired in parallel and series for a 12-volt system
See "Options and Optional Equipment" for battery options
 - 6.3.2. Voltage 6Vdc each
 - 6.3.3. Weight Approx. 60 lbs. (26kg) each
 - 6.3.4. Capacity 430 Ah total capacity @ 12Vdc
- 6.4. Remote charger
- 6.5. Function Plugs into a standard commercial power source to recharge batteries if battery voltage drops due to lack of sun for automated solar charging system
 - 6.5.1. Type 12-volt battery charger
 - 6.5.2. Location Inside battery box, mounted to divider panel on opposite side from batteries
 - 6.5.3. Output capacity 15A

- 6.5.4. Output voltage 13.2Vdc range “float” mode
 13.6Vdc range “absorption” mode
 14.2Vdc range “bulk” mode
- 6.5.5. Input voltage 105 to 135Vac, standard three-prong plug
- 6.5.6. Input frequency 50 to 60 Hz
- 6.5.7. Cooling Fan cooled when charger temperature reaches 95°F (35°C)
- 6.5.8. Protection Automotive-style replaceable fuses
- 6.6. Solar
- 6.6.1. Panels One high-efficiency multi-crystal photovoltaic solar module
- 6.6.2. Location Behind message sign, over tower. Solar panel array lies flat; rises and rotates with message sign. No shadowing effect on any trailer component.
- 6.6.3. Power output 85W
 See “Options and Optional Equipment” for solar options
- 6.6.4. Current 9.5A max. system current
 10.3A open short-circuit current
- 6.6.5. Voltage 17.9Vdc max.
 21.8Vdc open short-circuit voltage
- 6.6.6. Regulation Solar panels regulated by message sign control system
- 6.6.7. Security Solar panel array bolted to message sign frame with security screws and special security nut. Tool for security screws mounted inside battery box.

7. DIMENSIONS & WEIGHT

7.1. Dimensions

7.1.1. Large sign

*inches
(cm)*

Travel position

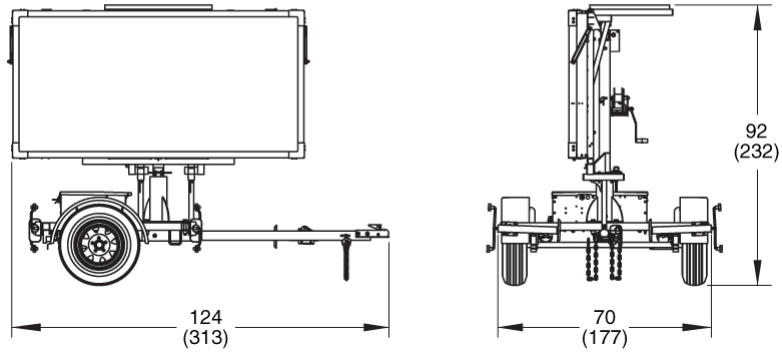

Deployed

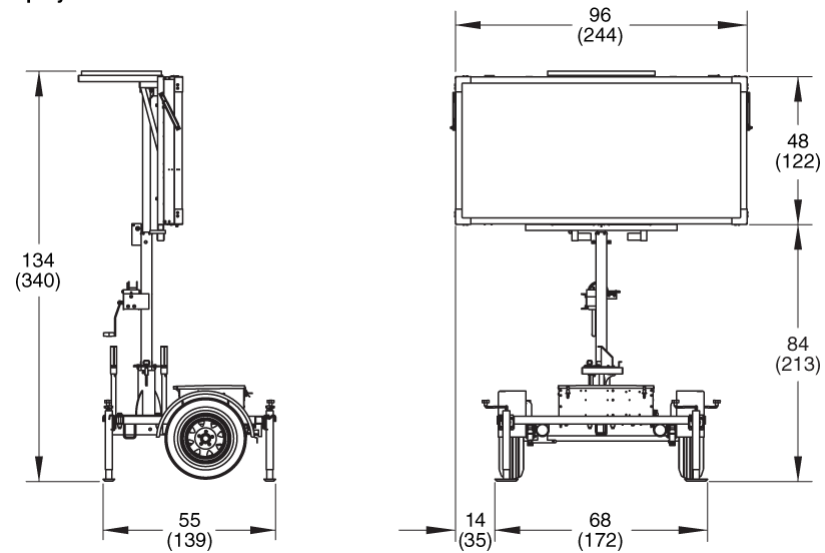

7.1.2. Medium sign

*inches
(cm)*

Travel position

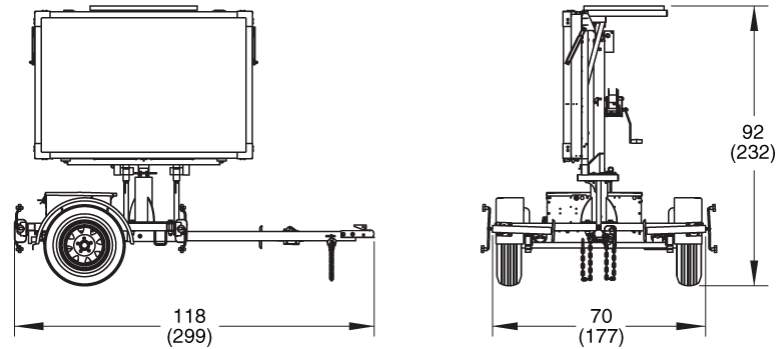

Deployed

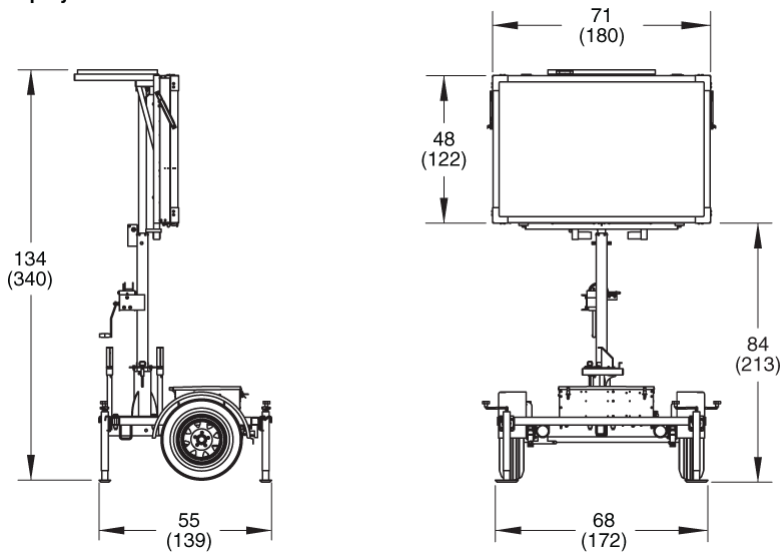

7.2. Weight

7.2.1. Large sign Approx. 1500 lbs. (680 kg)

7.2.2. Medium sign Approx. 1400 lbs. (635 kg)

8. OPTIONS AND OPTIONAL EQUIPMENT

- 8.1. Tow hitch** Combo-hitch for pintle hook and 2-inch ball hitch
Heavy-duty lunette ring, 2½" ID x 1½" cross-section
- 8.2. Tow-vehicle plug** Many types of plugs available, prewired at the factory; contact factory for details
- 8.3. Color display** Display modules with colored LEDs replace the standard amber modules.
Specifications for this option are provided in a separate document.
- 8.4. Rotation brake** For sign rotation lock, a mechanical friction caliper and disk brake replaces standard rotation lock mechanism. The ½-inch thick, round, zinc-plated brake disk is bolted to the outer tower section. An adjustable lever operates brake.
- 8.5. Power**
- 8.5.1. Additional batteries For geographic locations with less solar charging potential or colder weather, and for applications that require year-round charging, add batteries for greater capacity
- Option Two additional 6Vdc deep-cycle batteries, 215Ah additional capacity
- 8.5.2. AGM batteries Replace deep-cycle batteries with top-of-the-line absorbed glass mat (AGM) batteries
- Features 100% maintenance-free
Sealed and spill-proof
Faster recharge and greater freeze resistance than conventional batteries
Contains less lead than conventional batteries
- Options Two 4D AGM 12Vdc batteries, 400Ah total capacity
Three 4D AGM 12Vdc batteries, 600Ah total capacity
- Weight Approx. 160 lbs. (72kg) each
- 8.5.3. Remote charger When required for added battery charging capacity, replace standard remote charger with higher amperage charger
- Options 12-volt, 45-amp charger
12-volt, 75-amp charger
- Details Output voltage 13.4Vdc @ full load
13.6Vdc standard float voltage
14.2Vdc with dual-voltage jack installed
- Input voltage 108 to 132Vac, standard three-prong plug
- Input frequency 50 to 60 Hz

- 8.5.4. Solar For geographic locations with less solar charging potential or colder weather, and for applications that require year-round charging, additional solar power is available
Options include 170W and 255W solar arrays; contact factory for details
- 8.6. Secure battery box** High-security battery box features heavy-gauge steel lid, hidden hinges, and heavy-duty hidden-shackle padlocks. Replaces standard battery box.
- 8.7. Taillights**
- 8.7.1. Dual sealed-bulb Dual sealed-bulb taillights replace standard sealed-bulb taillights
Requires SAE J560 7-pole round-pin trailer plug to replace standard trailer plug
- 8.7.2. Single LED Single LED taillights replace standard sealed-bulb taillights
- 8.7.3. Dual LED Dual LED taillights replace standard sealed-bulb taillights
Requires SAE J560 7-pole round-pin trailer plug to replace standard trailer plug
- 8.8. Reflective tape** Reflective red-and-white conspicuity tape across rear trailer frame for increased visibility
- 8.9. Finish color** Specify power-coat color and, if applicable, color scheme
- 8.10. Radar-based speed monitoring system**
- 8.10.1. Description Radar senses the largest, nearest mass moving toward it. The message sign conveys a user-selected message to the motorist.
- 8.10.2. Sensor Microwave K-band, approach-only
- 8.10.3. Location Radar head located on the bottom of the message sign display cabinet, just off-center, for maximum effectiveness regardless of which side of the road the trailer is being used
- 8.10.4. Enclosure Radar head is sealed to withstand the elements, while an aluminum cover goes over the head unit for impact resistance
- 8.10.5. Standards compliance FCC approved
CE compliant
- 8.10.6. Distance range 1000 ft. (305 m)
- 8.10.7. Speed range 5 to 138 mph (8 to 222 km/h)
- 8.10.8. Accuracy mph ±1 mph from 5 to 40 mph
±2 mph from >40 to 100 mph
km/h ±1.6 km/h from 8 to 64 km/h
±3.2 km/h from >64 to 161 km/h
- 8.10.9. Electrical protection Fused and reverse-polarity protected
- 8.10.10. Calibration Calibration not required

8.11. Cellular modem package

8.11.1. Purpose		The remote communications package enables the message sign to be controlled from remote locations away from the message sign, using an Internet-connected computer, tablet, or smartphone. Includes all of the items described below.
8.11.2. Remote NTCIP central control software	Description	Easy-to-use program connects a computer to an individual message sign via an Internet connection. Used for changing messages, checking on trailer health status (such as battery voltages), viewing GPS locations, and setting message schedules.
	System requirements	Microsoft® Windows® (most versions) .NET framework Internet connection
8.11.3. Web-based remote control	Description	Using a standard Web browser, allows connection to an individual message sign without software. Ideal for smartphone users.
	System requirements	Modern standards-compliant Web browser with JavaScript enabled A platform that supports one of these browsers (smartphone, tablet, or computer) Internet connection
8.11.4. Wanco Fleet Manager	Description	Web-based application for managing even the most diverse message sign fleets
	Features	Add or remove equipment to groups for quick access, ideal for managing contractor rentals or entire projects all at once Map GPS locations of entire message sign fleet simultaneously Record vital information from signs, such as message changed by user and date, battery and solar voltages, and equipment alarms Mass broadcast capability, perfect for Amber Alerts and emergencies
	System requirements	Modern standards-compliant Web browser with JavaScript enabled A platform that supports one of these browsers (smartphone, tablet, or computer) Internet connection
8.11.5. Cellular plans	User provided	User obtains cellular data plan from, and makes monthly payments to, service provider. Wanco programs modem according to user-provided specifications at time of modem purchase. Wanco tests modem setup.
	Wanco cellular service	Wanco provides Verizon® cellular service without activation charges, monthly payments, or overage charges. User makes a single payment annually to Wanco. For increased security, Wanco hosts the service on a virtual private network (VPN).

- 8.11.6. Modem Compact industrial 3G cellular gateway with GPS
Variety of models; contact factory for details

8.12. Traffic Data Classifier System

- 8.12.1. Design Radar-based, nonintrusive, does not require loops or hoses, no disturbance of traffic flow during installation or use
- 8.12.2. Direction Registers both approaching and receding vehicles
- 8.12.3. Traffic lanes Most effective for 2-lane roads
- 8.12.4. Traffic count Can record data for up to 5 million vehicles in internal memory
- 8.12.5. Data format Speed, date, time, direction, length for each vehicle
- 8.12.6. Units English or metric
- 8.12.7. Time stamp Yr,Mo,Dy,Hr,Min,Sec.
- 8.12.8. Speed range 5 to 138 mph (8 to 222 km/h)
- 8.12.9. Sensor Microwave K-band 24.125 GHz
- 8.12.10. Power supply Message sign batteries
- 8.12.11. Power output 20 dbm (EIRP)
- 8.12.12. Current 110 mA
- 8.12.13. Internal memory 16GB
- 8.12.14. Baud rate 9600, 8 bit, no parity
- 8.12.15. Calibration Calibration not required
- 8.12.16. Regulatory rating FCC part 15 class A, Canadian RSS-210
- 8.12.17. Installation Automatically positioned horizontally when trailer is level; adjustable bracket allows user to point toward traffic at a 45-degree angle
- 8.12.18. Analytic software Wanco Traffic Analyzer

EXHIBIT A: MESSAGE FONTS

Large sign



Font 1

5 x 9 pixels

Equivalent size: 6.32" x 11.67" (160 x 296mm)

Physical size: 5.85" x 11.21" (149 x 285mm)

Standard fixed-width font with lower-case letters

3 lines of 10 characters, maximum



Font 2

5 x 9 pixels

Equivalent size: 6.32" x 11.67" (160 x 296mm)

Physical size: 5.85" x 11.21" (149 x 285mm)

Standard fixed-width font with lower-case letters and increased horizontal spacing

3 lines of 7 characters, maximum



Font 3

6 x 9 pixels

Equivalent size: 7.66" x 11.67" (194 x 296mm)

Physical size: 7.19" x 11.21" (183 x 285mm)

Bold proportional font with 4x9-pixel capitals for lower-case letters

3 lines of 8 characters, typical



Font 4

6 x 11 pixels

Equivalent size: 7.66" x 14.35" (194 x 364mm)

Physical size: 7.19" x 13.89" (183 x 353mm)

Bold proportional font with lower-case letters and accented characters

2 lines of 8 characters, typical



Font 5

6 x 11 pixels

Equivalent size: 7.66" x 14.35" (194 x 364mm)

Physical size: 7.19" x 13.89" (183 x 353mm)

Bold proportional font with lower-case letters, accented characters, and increased spacing

2 lines of 7 characters, typical



Font 6

5 x 14 pixels

Equivalent size: 6.32" x 18.37" (160 x 466mm)

Physical size: 5.85" x 17.90" (149 x 455mm)

Tall fixed-width font with 5x8-pixel capitals for lower-case letters

2 lines of 10 characters, maximum

Large sign (continued)



Font 7

7 x 12 pixels

Equivalent size: 9.00" x 15.69" (228 x 398mm)

Physical size: 8.53" x 15.22" (217 x 387mm)

Bold fixed-width font with 6x8-pixel capitals for lower-case letters
2 lines of 7 characters, maximum



Font 8

7 x 23 pixels

Equivalent size: 9.00" x 30.41" (228 x 772mm)

Physical size: 8.53" x 29.95" (217 x 761mm)

Large fixed-width font with 6x14-pixel capitals for lower-case letters
1 line of 7 characters, maximum



Font 9

11 x 23 pixels

Equivalent size: 14.35" x 30.41" (364 x 772mm)

Physical size: 13.89" x 29.95" (353 x 761mm)

Large bold fixed-width font, capitals only (no lower-case letters)
1 line of 5 characters, maximum



Font 10

4 x 5 pixels

Equivalent size: 4.98" x 6.32" (126 x 160mm)

Physical size: 4.52" x 5.85" (115 x 149mm)

Mini proportional font with limited lower-case
5 lines of 12 characters, typical
16 characters per line, maximum



Font 11

7 x 10 pixels

Equivalent size: 9.00" x 13.01" (228 x 330mm)

Physical size: 8.53" x 12.55" (217 x 319mm)

Large fixed-width font, capitals only (no lower-case letters)
2 lines of 6 characters, maximum



Font 12

9 x 14 pixels

Equivalent size: 11.67" x 18.37" (296 x 466mm)

Physical size: 11.21" x 17.90" (285 x 455mm)

Large bold fixed-width font, capitals only (no lower-case letters)
2 lines of 4 characters, maximum

Medium sign



Font 1

5 x 9 pixels

Equivalent size: 6.32" x 11.67" (160 x 296mm)

Physical size: 5.85" x 11.21" (149 x 285mm)

Standard fixed-width font with lower-case letters

3 lines of 8 characters, maximum



Font 2

5 x 9 pixels

Equivalent size: 6.32" x 11.67" (160 x 296mm)

Physical size: 5.85" x 11.21" (149 x 285mm)

Standard fixed-width font with lower-case letters and increased horizontal spacing

3 lines of 6 characters, maximum



Font 3

6 x 9 pixels

Equivalent size: 7.66" x 11.67" (194 x 296mm)

Physical size: 7.19" x 11.21" (183 x 285mm)

Bold proportional font with 4x9-pixel capitals for lower-case letters

3 lines of 7 characters, typical



Font 4

6 x 11 pixels

Equivalent size: 7.66" x 14.35" (194 x 364mm)

Physical size: 7.19" x 13.89" (183 x 353mm)

Bold proportional font with lower-case letters and accented characters

2 lines of 6 characters, typical



Font 5

6 x 11 pixels

Equivalent size: 7.66" x 14.35" (194 x 364mm)

Physical size: 7.19" x 13.89" (183 x 353mm)

Bold proportional font with lower-case letters, accented characters, and increased spacing

2 lines of 6 characters, typical



Font 6

5 x 14 pixels

Equivalent size: 6.32" x 18.37" (160 x 466mm)

Physical size: 5.85" x 17.90" (149 x 455mm)

Tall fixed-width font with 5x8-pixel capitals for lower-case letters

2 lines of 8 characters, maximum

Medium sign (continued)



Font 7

7 x 12 pixels

Equivalent size: 9.00" x 15.69" (228 x 398mm)

Physical size: 8.53" x 15.22" (217 x 387mm)

Bold fixed-width font with 6x8-pixel capitals for lower-case letters

2 lines of 6 characters, maximum



Font 8

7 x 23 pixels

Equivalent size: 9.00" x 30.41" (228 x 772mm)

Physical size: 8.53" x 29.95" (217 x 761mm)

Large fixed-width font with 6x14-pixel capitals for lower-case letters

1 line of 6 characters, maximum



Font 9

11 x 23 pixels

Equivalent size: 14.35" x 30.41" (364 x 772mm)

Physical size: 13.89" x 29.95" (353 x 761mm)

Large bold fixed-width font, capitals only (no lower-case letters)

1 line of 4 characters, maximum



Font 10

4 x 5 pixels

Equivalent size: 4.98" x 6.32" (126 x 160mm)

Physical size: 4.52" x 5.85" (115 x 149mm)

Mini proportional font with limited lower-case

5 lines of 10 characters, typical

14 characters per line, maximum



Font 11

7 x 10 pixels

Equivalent size: 9.00" x 13.01" (228 x 330mm)

Physical size: 8.53" x 12.55" (217 x 319mm)

Large fixed-width font, capitals only (no lower-case letters)

2 lines of 5 characters, maximum



Font 12

9 x 14 pixels

Equivalent size: 11.67" x 18.37" (296 x 466mm)

Physical size: 11.21" x 17.90" (285 x 455mm)

Large bold fixed-width font, capitals only (no lower-case letters)

2 lines of 3 characters, maximum

EXHIBIT B: ARROW-BOARD FUNCTIONS

Flashing patterns



Flashing left or right arrow



Flashing double arrow



Flashing four-corner warning



Flashing caution-bar warning

Sequential patterns



Sequencing left or right stem arrow



Sequencing left or right walking arrow



Sequencing left or right chevron arrows



Alternating diamonds